

This is a general specification leaflet; for specific applications not covered herein, contact Suntec.

The SUNTEC AL oil pump incorporates a blocking solenoid valve with in-line cut-off function.

APPLICATIONS

- Light oil, B10 heating oil/biofuel blend (as defined in DIN V51603-6) and kerosene.
- One or two-pipe system.

PUMP OPERATING PRINCIPLE

The gear set draws oil from the tank through the built-in filter and transfers it to the nozzle line via the cut-off solenoid valve. A pressure regulating valve is used to dump all oil which is not required at the nozzle.

In two-pipe operation, the by-pass plug must be fitted in the return port, which ensures that the oil dumped by the regulating valve is returned to the tank and the suction line flow is equal to the gear set capacity.

In one-pipe operation, the oil which does not go through the nozzle line is returned directly to the gear inlet and the suction line flow is equal to the nozzle flow. In that case, the by-pass plug must be removed from the return port, and the return port sealed by steel plug and washer.

Bleed

Bleeding in two-pipe operation is automatic : it is assured by a bleed flat on the piston.

In one-pipe operation, the plug of a pressure gauge port must be loosened until the air is evacuated from the system.

Cut-off

The solenoid valve of the AL pump is of the "normally closed" type and is situated in the nozzle line. This design ensures extremely fast response and the switching can be selected according to the burner operating sequence and is independant of motor speed.

When the solenoid is non-activated, the valve is closed and all oil pressurised by the gear set passes through the regulator to the suction or return line, depending upon pipe arrangement.

As soon as the solenoid is activated, oil passes to the nozzle line at the pressure set by the pressure regulating valve.

PUMP IDENTIFICATION

(Not all model combinations are available
Consult your Suntec representative)

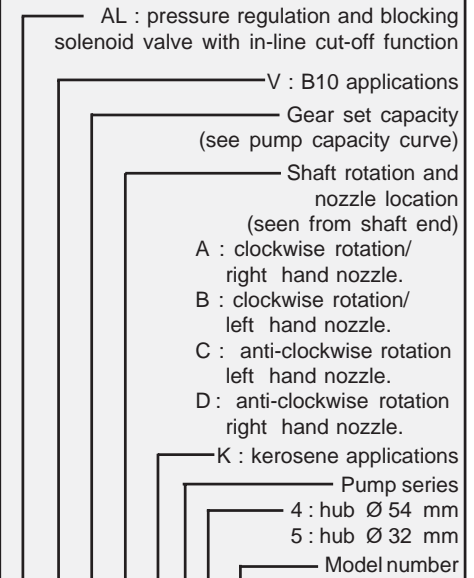

AL V 35 C K 9 5 xx 6 P 05 00

- Revision number
- Installation
- P: by-pass plug inserted in return port for two-pipe operation
- M: without by-pass plug, return plugged, for one-pipe operation
- Solenoid valve voltage
- 06 : 110-120 V ; 50/60 Hz
- 02 : 24 V ; 50/60 Hz
- 05/07 : 220-240 V ; 50/60 Hz
- Connector cable length
- 00 : no cable
- 35 : 35 cm cable - 45 : 45 cm cable
- 60 : 60 cm cable - 10 : 1 m cable

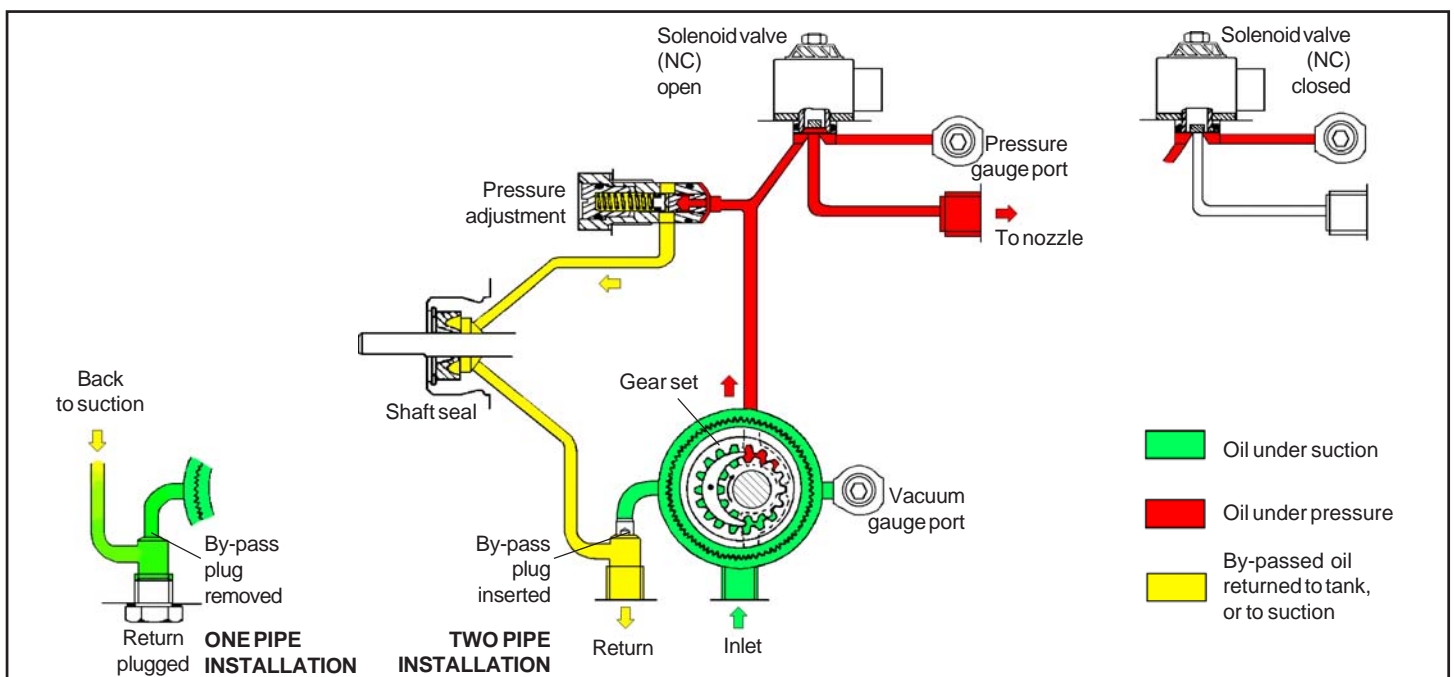

TECHNICAL DATA

General

Mounting	Hub mounting according to EN 225. (Flange mounting available on AL 75/75K/95/95K models)	
Connection threads	cylindrical according to ISO 228/1.	
Inlet and return	G 1/4	(with facilities for conical sealing on revision 6 models)
Nozzle outlet	G 1/8	
Pressure gauge port	G 1/8	
Vacuum gauge port	G 1/8	
Valve function	Pressure regulation.	
Strainer	open area : 6 cm ² (AL 35/35K/55/55K/65/65K) 20 cm ² (AL 75/75K/95/95K). opening size : 150 μm.	
Shaft	Ø 8 mm according to EN 225.	
By-pass plug	inserted in return port for two-pipe system ; to be removed with a 4 mm Allen key for one pipe system.	
Weight	1,1- 1,3 kg (depending on the model).	

Hydraulic Data

Gear size	Nozzle pressure range*	Factory setting
35/55/65/75	4 - 18 or 8 - 15 bars @ 5 cSt	9 or 12 bars
95	4 - 18 or 10 - 20 bars @ 5 cSt	9 bars
35K/55K/65K/75K/95K	8 - 15 bars @ 1,8 cSt	12 bars

* other ranges available on request, refer to the specified range of the particular fuel unit.

Operating viscosity	Oil temperature
2 - 12 mm ² /s (cSt) for AL 35/55/65/75/95	0 - 60°C in the pump.
1,25 - 12 mm ² /s (cSt) for AL 35K/55K/65K/75K/95K	

Inlet pressure	Return pressure	Suction height	Rated speed	Torque (@ 45 rpm)
2 bars max.	2 bars max.	0,45 bars max. vacuum to prevent air separation from oil	3600 rpm max.	0,10 N.m (AL 35/35K/55/55K) - 0,12 N.m (AL 65/65K) 0,14 N.m (AL 75/75K) - 0,20 N.m (AL 95/95K)

Solenoid valve characteristics

Voltage	220-240 or 110-120 or 24 V; 50/60 Hz
Consumption	9 W max.
Coil Code*	Ambiant temperature
06/02/05	0 - 60 °C
07	0 - 80 °C

* Refer to "Pump identification - solenoid coil voltage".

Maximum pressure	25 bars
Certified	TÜV Nr stamped on pump cover.
Protection class	IP 54 according to EN 60529, when used with SUNTEC connector cable.

PUMP DIMENSIONS

Examples show "C" rotation and nozzle outlet.

Pumps revision 4,6

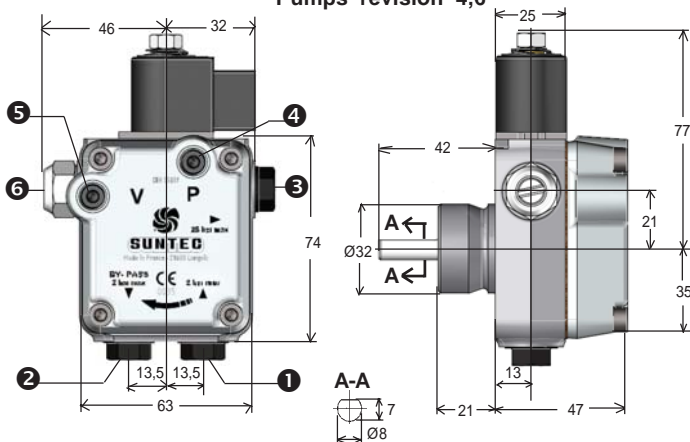

Inlet ① and Return ② with direct sealing for revision 6 models (sealing with washers can also be used)

Pumps revision 2

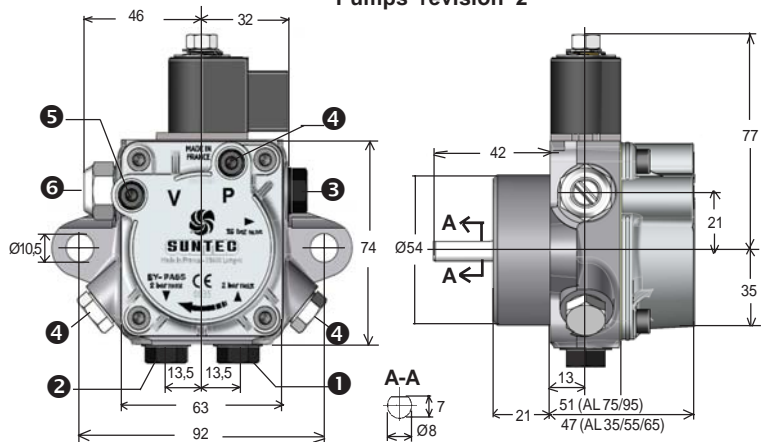

- ① Suction
- ② Return and internal by-pass plug
- ③ Nozzle outlet
- ④ Pressure gauge port
- ⑤ Vacuum gauge port
- ⑥ Pressure adjustment

Pump capacity

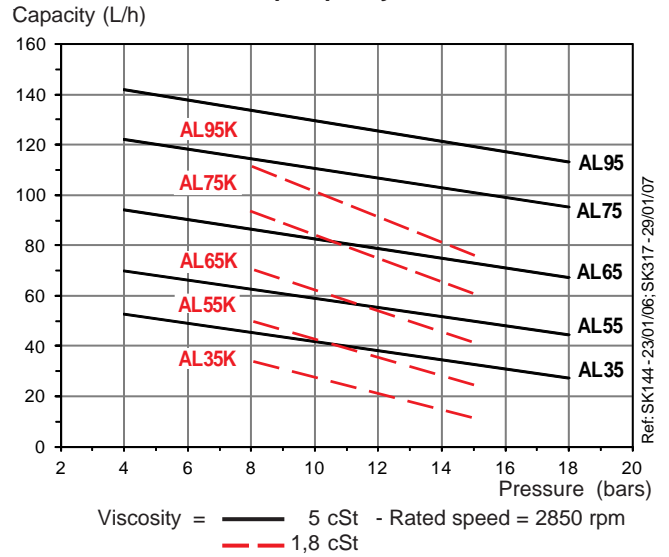

Data shown take into account a wear margin.
Do not oversize the pump when selecting the gear capacity.

Power consumption

